

UV INSPECTION LAMP

Technical Overview

Conformal coating solutions made easy

Want to help your conformal coating inspection process? Use a UV magnifier

The inspection lamp has a magnification of 5 Diopters and UV fluorescent bulb that provides the perfect inspection environment for operators and inspectors for the conformal coating process.

0-hour specification; Intensity 25 mW/cm² at a distance of 15 cm and an intensity of 10 mW/cm² at a distance of 30 cm. Usage of the lamp is not allowed after a decreasing of the intensity with 20%

Standard Features

- Ultraviolet light between 320 - 405 nm
- Magnification 2.9X (5 diopters)
- Optic is circular glass lens
- Dimmable None
- UV fluorescent LED bulb
- Table clamp included
- ESD safe

Options

- Reduced magnification 1.75X (3 diopters)

Facilities

14W Led.

Contact us now

Find out how we can help you with your conformal coating inspection process and save you time and money now.

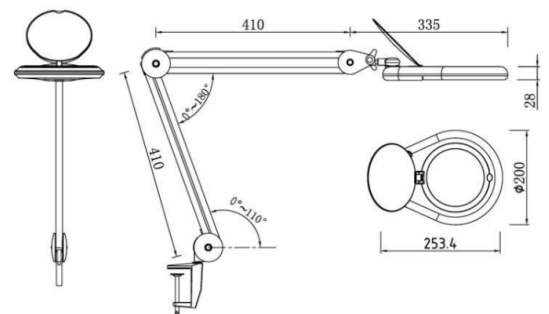

SCH Coating Solutions Pvt. Ltd.
11-1-128, Sitaphalmandi, Secunderabad
500061, T.S., INDIA.
Email : admin.ind@schservices.com
Landline : +91-91006 45359

For further enquiries, please contact

 **+91-9000383674**

www.conformalcoating.co.uk
www.conformalcoating.in



Scan QR
for more
information



 [schtechnologies](https://www.facebook.com/schtechnologies)